

Application of MV XLPE unarmoured single core cables

This bulletin serves to highlight the risks associated with the application of standard SANS 1339 MV XLPE unarmoured single core cables, particularly where a copper tape screen and PVC outer sheath is specified in the design and construction of the cable. Such a cable construction is often specified by EPC consultants for Wind Farm and Solar Farm installations. A technically more superior alternative MV XLPE unarmoured single core cable that uses a copper wire screen and an MDPE outer sheath is recommended. A longitudinal water blocked design including water blocking of the conductor is also recommended.

Single core MV XLPE unarmoured cables rated between 3.8/6.6kV to 19/33kV, with a standard aluminium conductor, XLPE insulation, copper tape screen and PVC outer sheath is often specified by EPC consultants for use in Wind Farm and Solar Farm applications. Such a cable construction, illustrated in Figure 1, is classed as an unarmoured Type B cable in accordance with SANS 1339.

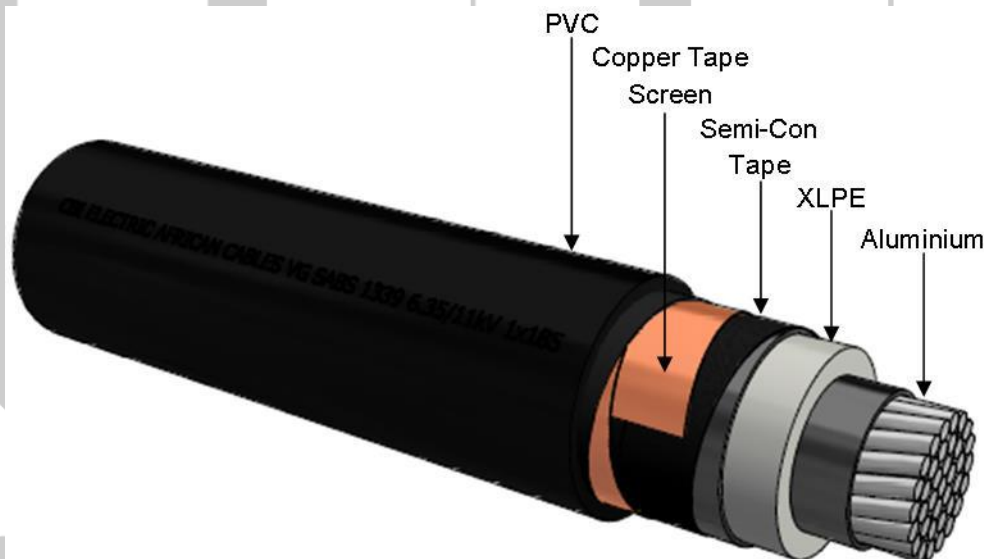

Figure 1: Typical construction of the standard MV XLPE unarmoured single core cable (Not recommended by CBI-electric: african cables).

Three major potential technical risks with this cable construction have been identified as listed below:

1. The copper tape screen in a single core and unarmoured design is prone to tears during installation (bending, compaction) and during the normal load cycling (thermal expansion and contraction) of the cable. Any tears in the copper tape screen will compromise its electrical continuity affecting the earth path. This earth path carries the charging current under normal operation. This current can be 1 to 2 A/km on a 33kV cable. The resulting persistent arcing will cause degradation. Another concern is the cable downstream of the tear will be unearthed. The floating voltage resulting from the capacitive coupling effect will elevate the potential on the copper tape and cause arcing across the tear. The heat generated and burning from such arcing will result in premature insulation degradation and damage to the cable.

2. The PVC outer sheath has limitations:

- 2.1. Without an underlying armouring it is not adequate to offer sufficient mechanical protection during installation (laying and compacting).
- 2.2. It is also susceptible to attack by termites since it is a relatively soft material.
- 2.3. It is also permeable. Water will diffuse into the cable in a matter of time. Water in contact with XLPE insulation is not recommended due to the risk of water tree growth.

3. The cable is not water blocked placing the insulation at risk of water tree growth should water enter the cable either by natural diffusion through the PVC outer sheath or in the event of a cable fault or external damage. This may be a more of a risk if the cables must traverse water courses along the route.

Although such a cable construction is covered in SANS 1339, taking the above risks into consideration, Cbi-electric: african cables does not recommend the application of such a cable as the performance, longevity and reliability of the MV installation will be at risk.

Cbi-electric: african cables will raise and address this matter through the Association of Electrical Cable Manufacturers of South Africa (AECMSA) with the intention to make a recommendation to SABS TC66 to withdraw such a design construction from the standard.

In order to address the three major risks associated with the above design, Cbi-electric: african cables highly recommends our alternative MV XLPE cable design as illustrated in Figure 2. This design comprises a copper wire screen instead of a copper tape screen that is of equivalent electrical area, short circuit rating and which is in accordance with SANS 1339. The copper wire screen will not break or tear during thermal expansion and contraction of the cable during normal load cycling operation.

A Medium Density Polyethylene (MDPE) outer sheath is offered in place of PVC which is in accordance with SANS 1339. Due to the chemical bond structure of the MDPE sheath, it is more resistant to moisture ingress by diffusion thereby preventing water from naturally diffusing into the cable. It is also a much harder material offering better mechanical protection than PVC and better protection from termite attack.

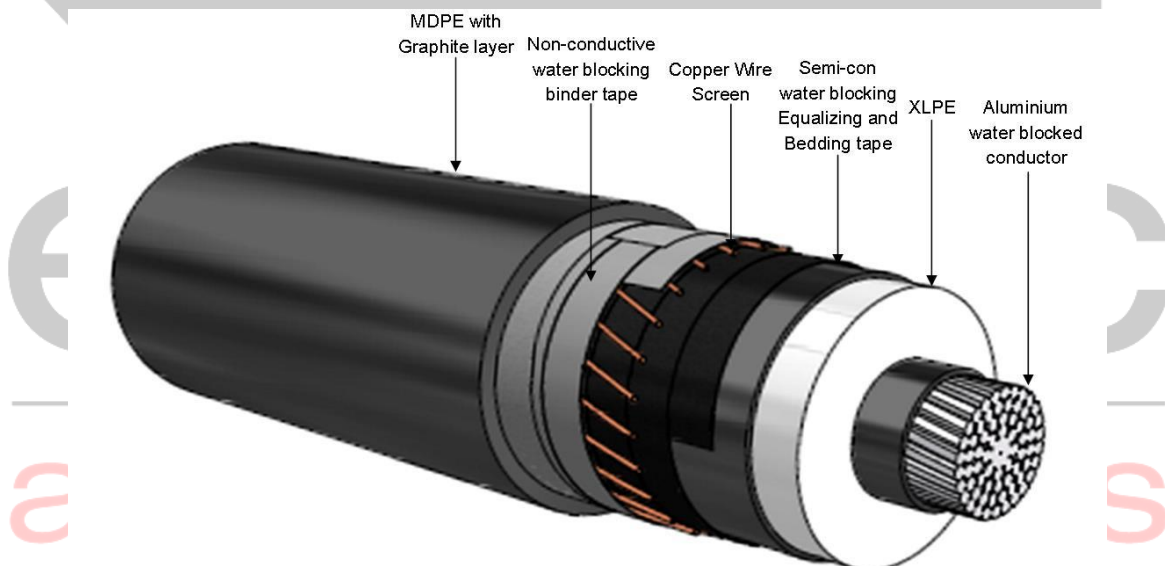

Figure 2: Typical construction of the alternative MV XLPE single core unarmoured cable recommended by Cbi-electric: african cables, particularly for Wind Farm and Solar Farm applications.

This design is also fully water blocked in both the conductor and copper wire screen. This ensures that if water enters the cable typically when there is a cable fault or external mechanical damage, it will not travel longitudinally along the length of the cable thereby protecting the XLPE insulation from contact with water. This limits the length of cable needing replacement in such an eventuality.

Compiled by:
Pravesh Haripersad
Snr. Design Engineer
29 November 2012



electric
african cables